

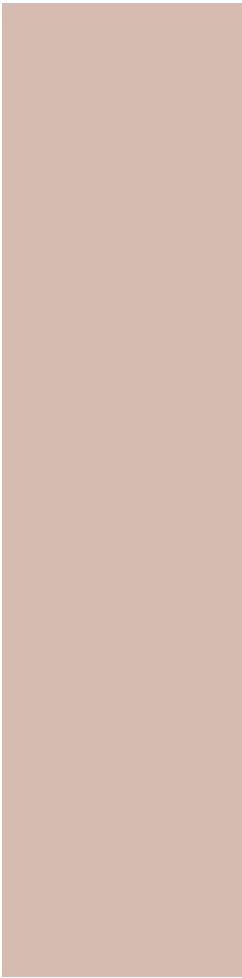

BLUE STAR



REFRIGERATION SOLUTIONS TO HELP
YOUR BUSINESS DO BETTER.



With over seven decades of experience, Blue Star, India's leader in air conditioning and refrigeration solutions brings diverse commercial refrigeration products and solutions to cater to the needs of customers. Be it a hotel, school, university hostel or eatery, our products serve as impeccable solutions every single time. To preserve food and keep it fresh for a long time, we bring you cutting-edge products like Reach-in Chillers and Freezers, Undercounter Chillers and Freezers, Modular Cold Rooms, Deep Freezers and Bottle Coolers. To cool water fast, we have the widest range of Storage Water Coolers on offer. These water coolers are available with different types of purification options. And with reliable refrigeration design, every product has been tested to perform in high ambient conditions.

Our entire range of refrigeration products meets high quality ISO standards to comply with today's hygiene and sanitary regulations. To meet the requirements of customers across the spectrum, Blue Star offers multiple models under each product category.



WORLD-CLASS MANUFACTURING

Blue Star's foray into manufacturing began in the 1940s from a small office in Forbes Street in Colaba, Mumbai. In the mid-1960s, we expanded our manufacturing base with a factory in Thane, Mumbai.

Today, Blue Star operates world-class manufacturing facilities at Dadra, Himachal Pradesh, Wada and Ahmedabad. With modern, state-of-the-art manufacturing technologies and equipment adhering to global quality standards and manufacturing processes, we have been delivering products of consistent quality both in India and international markets.

In all, we have a manufacturing footprint in excess of 1 lakh sq. mt. manufacturing over 300 models across 25 product lines.



Wada



Himachal Pradesh



Dadra



Ahmedabad

Wada Factory



Panel Punching Machine



QUALITY ASSURANCE

At Blue Star, we believe that quality is not just a policy but a way of life. We are deeply committed to delivering quality products and services and are constantly looking for new ways to achieve this.

We have rigorous quality checks in place for our manufacturing process in Commercial Refrigeration. And this is backed by various certifications, registrations and compliances from internationally acclaimed bodies.

CERTIFICATIONS

Our manufacturing facility at Wada, India has been awarded a Green Building Certification for being eco-friendly and zero polluting.

All our manufacturing facilities are also ISO 9001:2008 quality certified for the entire manufacturing and product output process.



RESEARCH & DEVELOPMENT

Blue Star is one of the pioneers in introducing advanced technology and applications to the Indian market.

As a philosophy, we focus on Digital Technology and Sustainability, with continuous investments and focused efforts in R&D. Backed by a new-age infrastructure, we take pride in having one of the best R&D centres in the Indian Commercial Refrigeration industry. Our R&D facility is recognised by the Department of Scientific & Industrial Research (DSIR), Government of India.

The R&D division caters to our Indian and global businesses while also designing products as an original design manufacturer (ODM) for several international brands. Significant investments have been made in building performance and reliability labs, virtual modelling and virtual performance testing softwares among other technologies. Our chiller test labs are AHRI certified and NABL-accredited with regard to room air conditioners and ducted systems.

We have six registered designs and have applied for 30 patents. Our technical capabilities are recognised by the policy making departments of the Government of India, and we play a vital role in developing standards for energy efficiency and safety, representing the industry across national and international forums. In other words, R&D is always an integral part of our business.





The R&D facility also has psychrometric test facilities to conduct performance tests in line with international testing standards.

ENSURING AN EXCELLENT FINISH

Our production facilities use raw materials that meet the highest quality standards. The equipment used to process the steel includes CNC machines such as the Amada punch press, hydraulic press and specialised microprocessor-based protection and resistance welders. All these machines ensure superior quality in cabinet fabrication with tight tolerances.

AFTER-SALES SUPPORT - BLUE STAR CARE

We set the standard for modern after-sales services, to ensure that you get the longest lifespan and best performance out of your products. BLUE STAR CARE is tailored to meet customer needs and deliver a world-class customer experience.

BENEFITS OF BLUE STAR CARE



Wide Service Network

With over 500+ authorised service centres spread across the country, our customer care network assures you timely service for every call.



24 x 7 Customer Call Centre

You can call us on our toll-free numbers 1800 209 1177 or 1860 266 6666 or SMS "Service" to 57575 or mail us at customerservice@bluestarindia.com any time of the day (or night) for immediate registration of complaints and for a committed response and resolution.





Technical Competence

With both the right knowledge and modern-day methods of service, we ensure you're offered expert resolutions to technical issues faced with your refrigeration devices and solutions.



Mobile Apps

You can log a call in *just 10 seconds* with our customer care app. Our field experts then receive service requests on their mobile devices and close the service calls through a mobile app with the proper authentication from your side.



Service On Wheels

We have over 100 service-crew vehicles in the field to serve you faster and better.





PROFESSIONAL REFRIGERATION PRODUCTS

Whenever you want fresh to remain fresh.

Commercial refrigeration is our forte, with over thirty years of experience backing us. We have understood the market over the years and are aware that customers look for tools and instruments that are functional, efficient and versatile, the kind that can help in their daily work. So we built products that can meet their needs with ease. By offering reliable, functional and diversified products and applications, we have won their trust and confidence over the years.

REACH-IN CHILLERS AND FREEZERS

Easy storage meets accurate temperature control.

These products are designed and tested to deliver optimum performance in harsh Indian conditions like high ambient temperature, rough usage, transportation and high humidity. Designed by Italian experts and manufactured to strict quality and production standards, these products have been tested at internationally accredited labs. The Controllers used by us are from internationally acclaimed brands. Testing is carried out to bring out the true performance of the product from various standpoints like reliability, transportation conditions to be encountered, electrical fluctuations and the entire life cycle. The stainless steel used is of food grade quality. The inner lining is made with SS 304 which makes it safe even if food accidentally comes into contact with the inner surface. These units can also be offered with the option of SS shelves.

FEATURES



Tropicalised for high ambient temperatures



Eco-friendly refrigerant



Food grade stainless steel unit



Odourless operation due to continuous air circulation



Uniform cooling by forced air circulation



Self-closing doors



Rounded corners



Adjustable tray slides



Auto defrost



Removable gasket for easy cleaning







Technical Specifications

Description	Units	Reach-in Freezers			
		RFSD640A	RF2D640A	RFDD1390A	RF4D1390A
Capacity	Ltr.	600	600	1300	1300
Temperature Range		-18°C ~ -22°C	-18°C ~ -22°C	-18°C ~ -22°C	-18°C ~ -22°C
No. of Doors	Nos.	1	2	2	4
Shelves	Nos.	3	3	6	6
Internal Light	Nos.	1 LED (4.8 Watts)	1 LED (4.8 Watts)	2 LED (9.6 Watts)	2 LED (9.6 Watts)
Refrigerant	Type / Charge (Grams)	R404A / 290	R404A / 290	R404A / 440	R404A / 440
Power Supply	V/Hz	220-240V / 50 Hz	220-240V / 50Hz	220-240V / 50Hz	220-240V / 50Hz
Max. Input Power	W	750	750	880	880
Current	A	7.1	7.1	8.5	8.5
Defrost		Automatic	Automatic	Automatic	Automatic
Thermostat Control		Digital	Digital	Digital	Digital
Overall Dimensions (W x D x H)	mm	700 x 820 x 2050	700 x 820 x 2050	1400 x 820 x 2050	1400 x 820 x 2050
Net Weight	kg	118	127	194	192

Technical Specifications

Reach-in Chillers					
Description	Units	RCSD640A	RC2D640A	RCDD1390A	RC4D1390A
Capacity	Ltr.	600	600	1300	1300
Temperature Range		2°C ~ 8°C	2° ~ 8°C	2° ~ 8°C	2° ~ 8°C
No. of Doors	Nos.	1	2	2	4
Shelves	Nos.	3	3	6	6
Internal Light	Nos.	1 LED (4.8 Watts)	1 LED (4.8 Watts)	2 LED (9.6 Watts)	2 LED (9.6 Watts)
Refrigerant	Type / Charge (Grams)	R134A / 250	R134A / 250	R134A / 300	R134A / 300
Power Supply	V/Hz	220-240V / 50 Hz	220-240V / 50Hz	220-240V / 50Hz	220-240V / 50Hz
Max. Input Power	W	322	322	524	524
Current	A	3.1	4.5	4.5	5.2
Defrost		Automatic	Automatic	Automatic	Automatic
Thermostat Control		Digital	Digital	Digital	Digital
Overall Dimensions (W x D x H)	mm	700 x 820 x 2050	700 x 820 x 2050	1400 x 820 x 2050	1400 x 820 x 2050
Net Weight	kg	114	122	186	187



UNDERCOUNTER CHILLERS AND FREEZERS

High performance comes with a heavy-duty build.

Blue Star's range of Undercounter Chillers and Freezers is ideal for storing pre-mixes and preparation materials. This range comes with an auto door-close mechanism and uses food grade stainless steel to keep food fresh.

These Undercounter Chillers and Freezers provide precise temperatures, are designed aesthetically and built for heavy-duty use.

Also available in the Undercounters range are Pizza Tables, Saladette Range, Sandwich Stations and Chilled Topping Units.



FEATURES



Tropicalised for high ambient temperatures



Eco-friendly refrigerant



Food grade stainless steel unit



Odourless operation due to continuous air circulation



Uniform cooling by forced air circulation



Self-closing doors





FEATURES



Rounded corners



Adjustable tray slides



Auto defrost



Removable gasket for
easy cleaning



Digital temperature
indicator



Door options : Stainless
Steel / Glass





Technical Specifications

DESCRIPTION	UNITS	UC2100A	UC3100A
Capacity	Ltr.	313	465
Temperature Range		2°C to 8°C	
No. of Doors	Nos	2	3
Type of Doors		SS / Glass	
Refrigerant	Type / Charge (Grams)	R134a / 230	
Power Supply	V/Hz	220-240V, 50Hz	
Max Input Power	W	350 Watts	
Current	A	1.95A	
Defrost		Automatic	
Thermostat		Digital	
Overall Dimensions (W X D X H)	mm	1360 X 700 X 860	1795 X 700 X 860
Net Weight	kg	98	134



Technical Specifications

DESCRIPTION	UNITS	UF2100A	UF3100A
Capacity	Ltr.	313	465
Temperature Range		-18°C to -22°C	
No. of Doors	Nos	2	3
Type of Doors		SS / Glass	
Refrigerant	Type / Charge (Grams)	R404a / 300	
Power Supply	V/Hz	220-240V, 50Hz	
Max Input Power	W	750 Watts	
Current	A	3.5A	
Defrost		Automatic	
Thermostat		Digital	
Overall Dimensions (W X D X H)	mm	1360 X 700 X 860	1795 X 700 X 860
Net Weight	kg	103	137



SALADETTES AND SANDWICH STATIONS

Blue Star now introduces Saladettes and Sandwich Stations to its range of products. They are built from stainless steel on the interior as well as exterior to give a great aesthetic appeal and to differ from other models available in the market. A definite boost to the eatery business!

FEATURES



Easy serviceability



Adjustable feet



High efficiency and functionality



Removable gasket



Green refrigerant



Cyclopentane blowing agent



Self-closing doors



45 mm thick insulation



Curved edge for easy cleaning



Digital temperature control



Automatic defrost

Technical Specifications

	Stainless Steel Top		Sandwich Top	
	SC2100B	SC3100B	SC2100A	SC3100A
External Dimensions (WxDxH) mm	900x700x882	1365x700x882	900x700x1005	1365x700x1005
Internal Dimensions (WxDxH) mm	810x586x492	1275x586x492	810x586x620	1275x586x620
Capacity (L)	159	239	227	376
Temperature Range	0°C to +8°C	0°C to +8°C	0°C to +8°C	+2°C to +8°C
Refrigerant	R600a	R290	R600a	R290
Defrost	Automatic	Automatic	Automatic	Automatic
Input Power (W)	142.4	230	142.4	230
Self-closing doors	2	3	2	3
Exterior and Interior	Stainless Steel	Stainless Steel	Stainless Steel	Stainless Steel
GN1/1 Shelves	-	-	2	3
Insulation Thickness (mm)	45	45	45	45
Net Weight (Kg)	87	106	84	112







BLAST FREEZERS

Blue Star offers a new range of Blast Freezers ideal for extremely fast chilling needs. These freezers help eliminate contamination from bacteria and maintain the quality of food products. A must-have product for any kitchen, they also prevent any weight loss of food products.

FEATURES



Internal /external construction
made of stainless steel AISI 304



Tropicalised for Indian conditions



Automatic defrosting system with pause



Electronic temperature display



High performance



Technical Specifications

	BF03G	BF05G	BF10G	BF15G
External Dimensions (WxDxH)	650 x 670 x 670	800 x 700 x 900	800 x 780 x 1700	800 x 780 x 2000
Net Weight (Kg)	65	92	145	175
Trays Capacity	3 GN 1/1	5 GN 1/1	10 GN 1/1	15 GN 1/1
Trays Pitch	67 mm			
Yield	+90/+3 °C = 10 kg +90/-18 °C = 7 kg	+90/+3 °C = 18 kg +90/-18 °C = 11 kg	+90/+3 °C = 34 kg +90/-18 °C = 22 kg	+90/+3 °C = 50 kg +90/-18 °C = 38 kg
Max Absorbed Power	975 W	1185 W	2010 W	3820 W
Refrigerated Power	613 W	807 W	1547 W	2933 W
Refrigerant	R404a			
Defrost	Automatic with Pause			Automatic with hot gas
Supply	230V/50Hz/1Ph			



Technical Specifications

	BF05F	BF07F	BF10F	BF15F
External Dimensions (WxDxH)	800 x 750 x 850	800 x 750 x 1210	800 x 750 x 1390	800 x 850 x 2000
Net Weight (kg)	80	110	140	180
Trays Capacity	5 GN1/1	7 GN1/1	10 GN1/1	14 GN1/1
Yield	+90/+3 °C = 20 kg +90/-18 °C = 15 kg	+90/+3 °C = 25 kg +90/-18 °C = 20 kg	+90/+3 °C = 30 kg +90/-18 °C = 25 kg	+90/+3 °C = 35 kg +90/-18 °C = 30 kg
Max Absorbed Power	1000 W	1200 W	2000 W	3500 W
Refrigerant	R404a / R507a			
Supply	220V/50Hz/1Ph			



BACK BAR CHILLER

Blue Star offers Back Bar Chiller options that can be used at any bar, club and/or restaurant. With glass doors, they provide excellent visibility and are designed to save space. Storage in these chillers ensures great preservation and convenient, ready-to-serve drinks.



FEATURES



Self-closing doors



Replaceable gasket



Internal LED light for better visibility



Adjustable shelves and feet



Lock fitted as standard



Safety tempered glass and double glazed doors



Digital temperature control



Technical Specifications

	BC250A	BC350A
Net Capacity (L)	201	320
External Dimensions(WxDxH mm)	900x520x900	1350x520x900
Internal Dimensions (WxDxH mm)	820x385x750	1260x385x750
Temperature Range	+1 to +10°C	+1 to +10°C
Input Power (W)	230	265
No. of Doors	2, Hinged	3, Hinged
Type of Cooling	Ventilated	Ventilated
Defrost	Automatic	Automatic
Refrigerant	R600a	R600a
Net Weight (kg)	62	80
Adjustable shelves	4	6
Insulation Thickness (mm)	40	40





ICE MACHINES

Ice of any shape. For any occasion.

Ice has diverse usage. A style element for cocktail drinks. A cool bedding for delicacies. A preserver of life saving drugs. This list is as long as it is diverse. And to meet your specific usage requirements of ice in the best possible way, you can always rely on the expert, Blue Star.

Why Blue Star?

Blue Star, India's leading refrigeration company, collaborates with NTF (Italy), the world's leading ice machines manufacturer, to bring new sophisticated ice-making machines. These machines are hygienic, energy efficient, durable and easy to maintain. Our expertise and domain knowledge gives you products according to your requirements. And our extensive service network ensures your machine's optimum performance and long life.

FEATURES



Power saving design



Perfect ice shapes



Water content control



Stainless steel body for longer life



Equipped with sprayers for easy cleaning



Compact design saves space



Auto Stop and Start

Diced Ice Makers

Keep your cocktails cool for a long time with our Diced Ice Makers. The cut cone shaped ice cubes are crystalline, compact and come with a higher staying power.



Bullet Ice Makers

Here's another option to cool your drinks perfectly. These Bullet Ice Makers quickly and efficiently produce hollow, bullet shaped ice. The bullet's soft touch, smooth surface and maximum cooling surface make it perfect for all kinds of drinks. What's more, it is capable of dealing with even the most hard water and provides a timer to gauge the entire production cycle.



Pyramid Ice Makers

Stylish to look at and quick to chill, our Pyramid Ice Makers produce seven-faceted pyramid ice that offers a refreshing break from the routine. It turns fizzy drinks into a chilled treat. What's more, these machines can produce great quantities of ice in a short span.



Technical Specifications

DESCRIPTION	UNITS	SL 35	SL 60	SL 90	SL 180	SL 260	SL 350	CM 650
Production in 24 hrs.	kg	20	29	43	88	100	155	300
Storage Capacity	kg	4	9	25	40	60	65	Customised
Cooling System		Air Cooled						
Weight of Cube	g	14	14/17/32/41					
Voltage / Frequency / Phase		230V ~ 50Hz -1 Ph						
Max input power	W	320	350	450	800	850	1400	2600
Overall Dimensions (W X D X H)	mm	350 x 445 x 690	390 X 517 X 705	496 X 629 X 795	735 x 603 x 907	737 X 640 X 1015	840 X 740 X 1075	1250 X 580 X 848
Net Weight	kg	30	38	52	71	74	118	152

Technical Specifications

DESCRIPTION	UNITS	IFT 65	IFT 165
Production in 24 hrs.	kg	35	75
Storage Capacity	kg	15	30
Cooling System		Air Cooled	
Weight of Cube	g	20	20
Voltage / Frequency / Phase		230V~50Hz-1 Ph	
Max input power	W	310	480
Overall Dimensions (W X D X H)	mm	495 x 580 x 687	735 x 596 x 907
Net Weight	kg	47	75

Technical Specifications

DESCRIPTION	UNITS	CV 475	CV 950	CV 1650
Production in 24 hrs.	kg	200	400	770
Cooling System		Air Cooled		
Weight of Cube	g	7		
Voltage / Frequency / Phase		230V ~ 50Hz -1 Ph		
Max input power	W	1600	3000	4300
Overall Dimensions (W X D X H)	mm	770 x 550 x 805		1250 x 645 x 950
Net Weight	kg	90	113	186



Snow Maker

Make a cool bedding for your delicacies or cool your drinks instantly with snow flakes made with our Snow Maker.



Technical Specifications

DESCRIPTION	UNITS	SM 1750	SM 4500
Production in 24 hrs.	kg	900	2300
Voltage / Frequency / Phase		230V ~ 50Hz -1 Ph	
Cooling System		Air Cooled	
Max input power	W	4600	7000
Overall Dimensions (W X D X H)	mm	1107 x 700 x 880	1062 x 832 x 1423
Net Weight	kg	241	520



Ice Flaker

Our Ice Flaker produces flat, sub-cooled flakes. Flakes are simple to store, handle and dose. And their superior staying power makes them ideal for processing, transportation and storage of food items.



Technical Specifications

DESCRIPTION	UNITS	SLF 190	SLF 320	GM 1200	GM 2000
Production in 24 hrs.	kg	95	155	510	1000
Storage Capacity	kg	19	38	-	-
Voltage / Frequency / Phase		230V ~ 50Hz -1 Ph			
Cooling System		Air Cooled			
Max input power	W	550	650	1700	3200
Overall Dimensions (W X D X H)	mm	496 x 660 x 685	741 x 678 x 925	560 x 569 x 695	934 x 684 x 700
Net Weight	kg	59	85	102	167

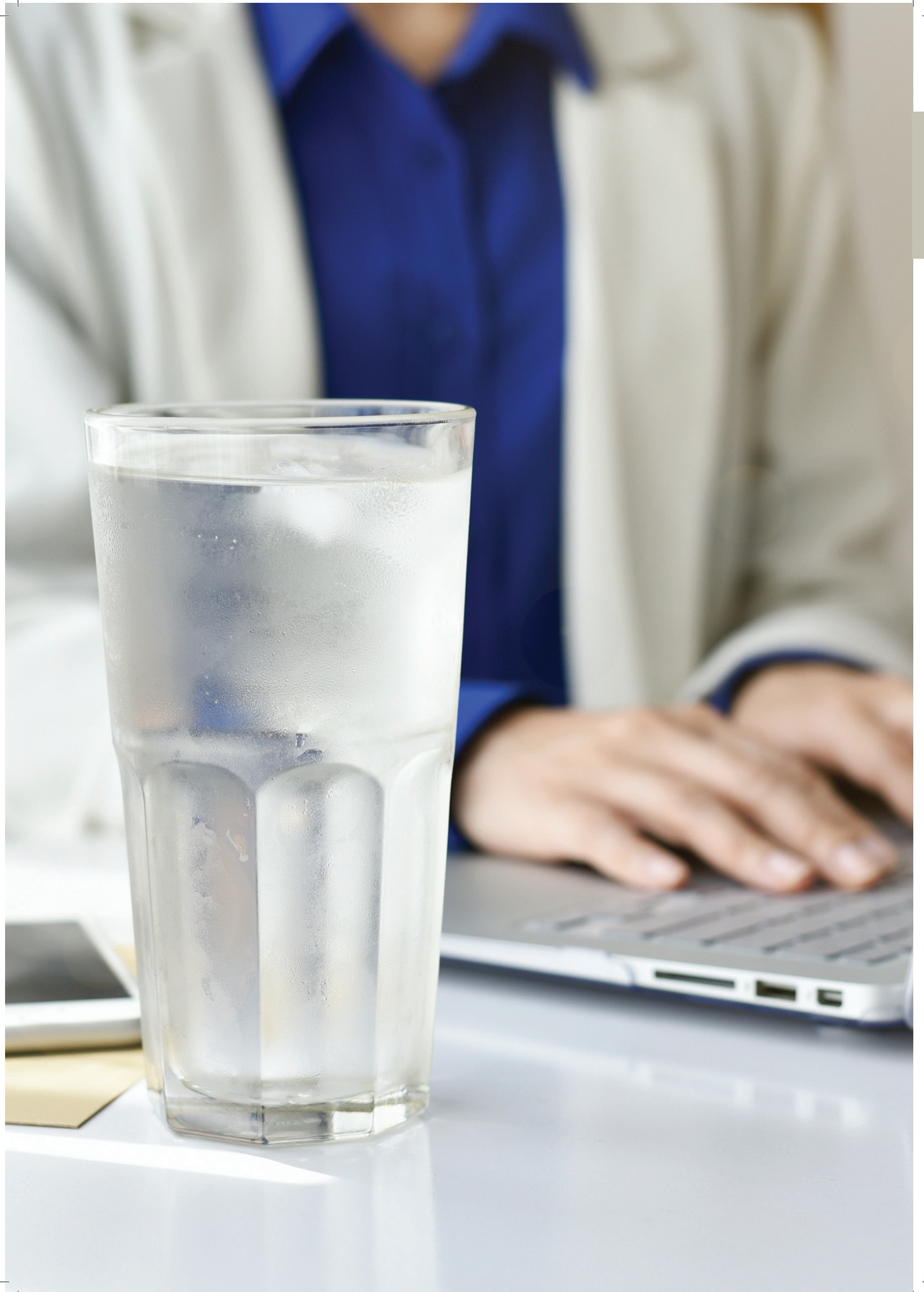

STORAGE WATER DISPENSER - PLATINUM SERIES

Hot, Cold & Room Temperature Water

Blue Star introduces a new range of Storage Water Dispenser - Platinum Series. The first of its kind in India, these Dispensers come with an in-built hot water faucet. They also dispense Cold Water and Room Temperature Water along with the option of UV & RO+UV purification. The Platinum Series is the one stop solution for all drinking water requirements.

FEATURES



Smart and ergonomical design



Cold/Room Temperature water



Hot water faucet with child lock



LED display



UV & RO+UV purification



Faster cooling



Eco-friendly refrigerant



In-situ power saving PUF insulation





Sturdy Compressor for trouble free operation



Nationwide Blue Star network for prompt service



Last point purification



Electronic eye



Fully automatic



Food grade SS Tank



PP outer body



Smart logic and troubleshooting



Technical Specifications

	DESCRIPTION	P6080E	P6080UVE	P6080UVROE
Performance Parameters	Storage Capacity (L)	80	80	80
	Capacity with Comfort Level Water Outlet Temp at 18°C at Rated Condition (L/hr)	60	60	60
	Storage Capacity - Cold	71	71	71
	Storage Capacity - Ambient	7	7	7
	Storage Capacity - Hot	2	2	2
	Total Running Current (A)	7.5	10	12.5
	Total Power (W)	1575	1630	1700
	Thermal Insulation for Tank	PUF	PUF	PUF
	No. of Faucets (Cold/Hot/Plain)	1/1/1	1/1/1	1/1/1
Filtration Stages	No. of Stages for Filter cum Purifier	-	1) Pre-Filtration 2) Pre-Carbon 3) Post-Filtration	1) Pre-Filtration 2) Pre-Carbon 3) Post-Filtration 4) RO 5) Post-Carbon
UV	UV Purification	-	Yes, Last Stage	Yes, Last Stage
RO System	RO Membrane Rating (L/hr)	-	-	400
	RO Membrane Operating Temperature	-	-	15°C to 45°C
	RO Membrane Flushing	-	-	Every 12 hours
	RO System and Water Cooler Operating Voltage	-	-	220-240 V
Body	Storage Tank Material	SS304	SS304	SS304
	Outer Body Material	Pre-Painted Sheet	Pre-Painted Sheet	Pre-Painted Sheet
	Type of Product Construction	Concealed	Concealed	Concealed
	Type of Installation	Indoor	Indoor	Indoor
	Top Lid Type	Hinged	Hinged	Hinged
Dimensions and Net Weight	Dimension (W x D x H) mm	660 x 575 x 1575	660 x 575 x 1575	660 x 575 x 1575
	Net Weight (kg)	55	63	69
	Refrigerant	R134a	R134a	R134a



WATER COOLERS

Cools water surprisingly fast.

Blue Star offers you a range of water coolers that provides cool water in no time. Perfect for schools, colleges, offices and places where the consumption of water is frequent and high, these water coolers come with several features that give you great value for money.

Unmatched Features of Blue Star Water Coolers

FF

Faster cooling



Eco-friendly

PUF

In situ power-saving PUF insulation



Sturdy compressor and trouble-free operation



Silent operation



Nationwide Blue Star network for prompt service

SS

Food Grade SS tank and body

SS

Stainless Steel Body

Your water cooler will look new and attractive even after years of use. No rusting, no corrosion.

SS

Stainless Steel Tank

For safe drinking water, year after year.



Easy Controls

The externally mounted thermostat makes it easy to set water temperature. No need to open service panels.

XL



Speedy Drainage

The extra large, stainless steel water tray prevents splashing and ensures fast drainage of water.



Technical Specifications

Model	Storage Capacity (Litres)	Nominal Cooling Capacity (Litres/hr)	No. of Faucets	Dimensions (mm)			Weight (kg)	Normal Demand (glasses per hr.)	Refrigerant	Current (Amps)	Water Over Flow (Connections)	Type of Compressor
				Width	Depth	Height						
SDLx20-ET	20	20	1	400	400	1060	30	100	R134a	2.0	1/2 BSP	RECIP
SDLx240	40	20	1	440	440	1150	34	100	R134a	2.0	1/2 BSP	RECIP
SDLx480B	80	40	2	665	480	1210	47	200	R134a	2.5	1/2 BSP	RECIP
SDLx680B	80	60	2	665	480	1210	47	300	R134a	3.0	1/2 BSP	RECIP
SDLx8120	120	80	2	755	575	1240	62	400	R 22	3.8	1/2 BSP	RECIP
SDLx15150A	150	150	2	812	612	1210	66	750	R 22	8.1	1/2 BSP	ROTARY
SDLx100	380	170	4	1120	750	1500	95	850	R 22	8.0	1/2 BSP	ROTARY

Model	Storage Capacity (Litres)	Nominal Cooling Capacity (Litres/hr)	No. of Faucets 1 Plain+ 1 Cold	Dimensions (mm)			Weight (kg)	Normal Demand (glasses per hr.)	Refrigerant	Current (Amps)	Water Over Flow (Connections)	Type of Compressor
				Width	Depth	Height						
PC240	40	20	1P+1C	440	440	1150	34	100	R134a	2.0	1/2 BSP	RECIP
PC480	80	40	1P+1C	665	480	1210	47	200	R134a	2.5	1/2 BSP	RECIP
PC15150A-3T	150	150	1P+2C	812	612	1210	66	750	R 22	8.1	1/2 BSP	ROTARY

Model	Storage Capacity (Litres)	Nominal Cooling Capacity (Litres/hr)	No. of Faucets	Dimensions (mm)			Weight (kg)	Normal Demand (glasses per hr.)	Refrigerant	Current (Amps)	Water Over Flow (Connections)	Type of Compressor
				Width	Depth	Height						
NST2020	20	20	1	400	440	1060	30	100	R134a	2.0	1/2 BSP	RECIP
NST6080	80	60	2	665	480	1210	47	300	R 22	2.5	1/2 BSP	RECIP
NST80120	120	80	2	755	575	1240	62	400	R 22	3.8	1/2 BSP	RECIP
NST170150	150	170	2	812	612	1210	66	750	R 22	8.1	1/2 BSP	ROTARY



Purifies cool water just
before you drink it.



WATER COOLERS WITH IN-BUILT UV PURIFICATION

Now Enjoy Cold Drinking Water that is 100% Pure Too!

Blue Star is already a leader in the storage water cooler market, and now we bring you storage water coolers with an in-built purification and filtration process, that not only supplies non-stop cold water, but also ensures its purity for safe consumption. The technology and design are so well put together that they give you last-point purification. This prevents contamination even post the filtration stage and ensures safe drinking water at the faucet.

Impure drinking water is one of the main sources of infection, even mild poisoning in many cases. Hence, it is important to build purification processes into the water system. Our water coolers incorporate everything that is required – reliable cooling systems, purification and contaminant filtration – all within the same housing, integrating all systems for seamless, efficient operation. They are therefore comprehensive and compact solutions for safe, clean and cold drinking water.

Proven Filtration Techniques for the Purest Water



UV Purification

UV filters, using robust and reliable technology, ensure contamination-free, safe drinking water.



Multiple Stages of Filtration

Besides the UV stage, various other filters ensure clean, odourless, tasty drinking water.



Last-point Purification

Innovative design, using proven last-point UV technology, ensures that filtered water is not exposed to further contamination before delivery at the faucet.



Electronic Eye

Monitors purification process and stops water flow if the purification is inadequate.



Faster Cooling

Efficient design, including the rectangular tank and forced fin and tube condenser, maximises heat transfer and ensures faster cooling.



Lower Power Consumption

Consumes less power as compared to equivalent models due to its smart design.



High Throughput

Large tank and the overall system designed for high consumption volumes.



Longer Life

Non-corrosive SS outer body ensures longer life, brighter looks and smoother finish, while rugged plastic legs reduce corrosion of base.



Contamination-free Storage

Food grade SS 304 stainless steel inner tank keeps the stored water contamination-free.



Space Saving

Compact design saves precious real estate.



Reliability

Reciprocating compressor can operate under tough ambient conditions for long hours. And in case of failure, it can be repaired in most cases thus lowering maintenance costs.



Ease of Service

Thoughtfully designed so that all important components are individually and separately accessible for easy service and maintenance.



Blue Star Water Coolers with UV Purification

Ultraviolet (UV) rays are proven to be effective in killing harmful bacteria and microbes that may be present in drinking water. At the same time, the treated water retains all its minerals and salts.

This is why our water coolers use ultraviolet radiation as a pre-treatment to sterilise and disinfect the water before it is available at the faucet.

These coolers also come with a further two-step filtering process that removes physical impurities, colour, organic impurities and chlorine from the water before it is dispensed.

A unique feature of these coolers is the last-point purification that uses UV technology to ensure that the water dispensed remains pure and uncontaminated even during the post-filtration flow.



Unique 3-stage Purification Process

- Unique polypropylene yarn candle to remove physical impurities from input water.
- Activated carbon cartridge for removing colour, organic impurities and chlorine.
- UV disinfection chamber to disinfect waterborne disease-causing bacteria and viruses.

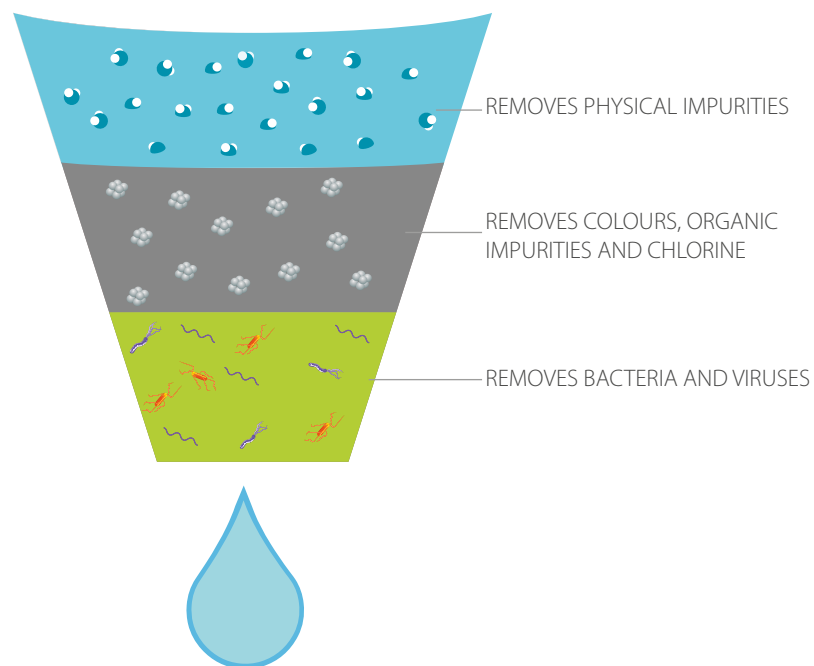

Technical Specifications

MODEL		SWCSDLX6080UVE	SWCNST80120UVE
Performance Parameters	Storage Capacity (up to float valve level)	80 Ltr.	120 Ltr.
	Capacity with Comfort Level Water Outlet Temp at 17°C ± 1°C at Rated Condition	60 LPH	80 LPH
	Running Current In AMPS (max) at Rated Condition	3.2 ± 10%	4 ± 10%
	Power in Watts (max) at Rated Condition	625 ± 10%	825 ± 10%
	Operating Power Supply	230 ± 10% V AC, 50Hz, 1 PH	
	Thermal Insulation for Storage Tank	PUF	
	No. of Faucets	2	3
	No. of Cold Water Faucets	1	2
	No. of Normal Water Faucets	1	
	Recommended Maximum Water Flow Rate through the Faucets in LPM	1.5	
Filtration Stages	No. of Stages	3	
	1st stage of Purification	Sediment filtration	
	2nd stage of Purification	Carbon filtration	
	3rd stage of Purification	UV filtration	
	No. of Purifier Circuit	2	3
	Visual Controls (LEDs)	Yes	
	Cooling on / off Switch	Yes	
	Operating Temperature	15°C to 45°C	
UV System	UV System & Water Cooler Operating Voltage	180 - 250V	
	Minimum Water input Pressure in Kg/mm ²	0.4	
	Maximum Water input Pressure in Kg/cm ²	2.0	
Body	Storage Tank Material	SS 304	
	Front Panel Material	SS 304	
	Side & Back Panel Material	SS 304	Pre-coated sheet
Dimensions & Net Weight	Dimensions (W x D x H) mm	660 x 480 x 1355	752 x 572 x 1400
	Net Weight (Kg)	65	85
Refrigerant	Refrigerant	R134a	



Pure, cool goodness
in every drop.



WATER COOLERS WITH IN-BUILT RO + UV PURIFICATION

Proven Filtration Techniques for the Purest Water

Unbeatable Features and Benefits

RO

RO Purification

RO filters using robust and reliable technology ensure contamination-free, safe drinking water.



7 Stages of Filtration

Besides RO, various other filters ensure clean, odourless, tasty and cool drinking water.

A

Fully Automatic

Starts or stops when the tank is half empty or full.



Faster Cooling

Efficient design, including rectangular tank and forced fin and tube condenser, maximises heat transfer and ensures faster cooling.



Lower Power Consumption

Consumes less power as compared to equivalent models due to its smart design.



High Throughput

Large tank and overall system designed for high consumption volumes.



Longer Life

Non-corrosive SS outer body ensures longer life, brighter look and smoother finish, while rugged plastic legs reduce corrosion of base.





Contamination-free Storage

Food grade SS 304 stainless steel inner tank keeps the stored water contamination-free.



Cold Water Even Through Power Cuts

In-situ PUF insulation not only reduces power consumption but ensures that the water remains cool even through long power failures.



Space Saving

Compact design saves precious real estate.



Reliability

Reciprocating compressor can operate under tough ambient conditions for long hours. And in case of failure, it can be repaired in most cases thus lowering maintenance costs.



Ease of Service

Thoughtfully designed so that all important components are individually and separately accessible for easy service and maintenance.

Unique 7-stage Purification Process

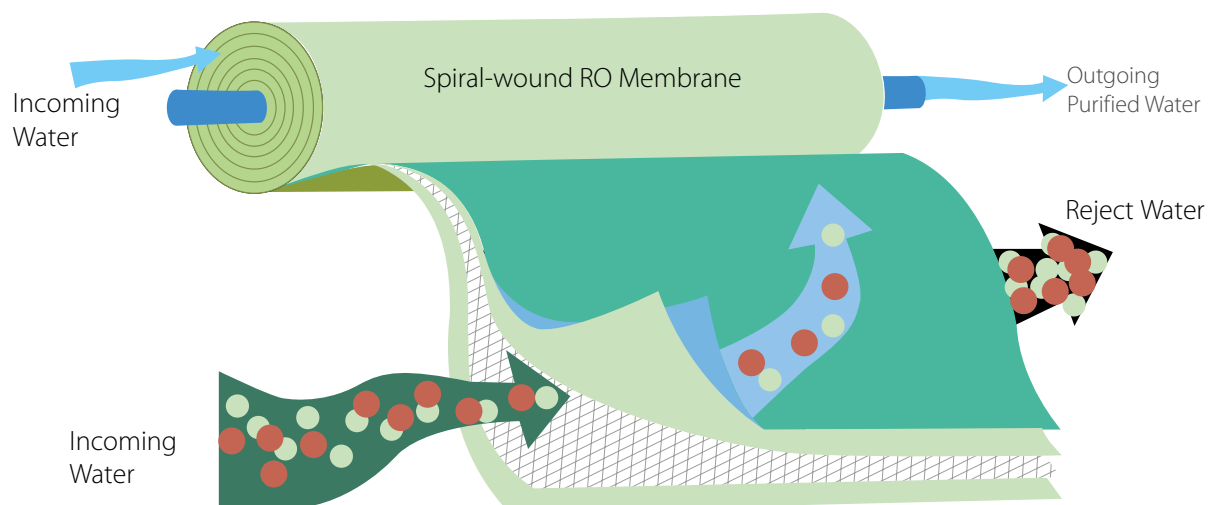

- Unique polypropylene yarn candle to remove physical impurities from input water.
- Specially treated pre-carbon block for absorbing colour, organic impurities and chlorine.
- Anti-scalant filters to prevent deposits over the RO membrane.
- The sediment filter traps all the fine sediments present in the input water.
- RO membrane filter (porosity of .0001 micron) strains micro-organisms and TDS from the input water.
- Post-carbon filter to enhance the taste of purified water.
- Nano-silver leaching effectively prevents microbial contamination in the storage tank.

Technical Specifications

Model		SWCSDLX6080UVROE
Performance Parameters	Storage Capacity (up to float valve level)	80 Ltr.
	Capacity with Comfort Level	60 LPH
	Water Outlet Temp at 17°C ± 1°C at Rated Condition	
	Running Current in AMPS (max) at Rated Condition	4.5 ± 10%
	Power in Watts (max) at Rated Condition	700 ± 10%
	Operating Power Supply	230 ± 10% V AC, 50Hz, 1 PH
	Thermal Insulation for Storage Tank	PUF
	No. of Faucets	2
	No. of Cold Water Faucets	2
No. of Normal Water Faucets	NA	
Recommended Maximum Water Flow Rate through the Faucets in LPM	50 LPH	
Filtration stages	No. of Stages for Filter cum Purifier	7
	1st Stage of Purification	Sediment purification
	2nd Stage of Purification	Carbon block purification
	3rd Stage of Purification	Anti-scalant purification
	4th Stage of Purification	Sediment purification
	5th Stage of Purification	Reverse Osmosis membrane purification (2 per circuit)
	6th Stage of Purification	Post-carbon block filtration
	7th Stage of Purification	Nano-silver leaching filtration
UV Purification	Yes	
RO system	RO Membrane Rating	4 x 75 GPD or equivalent
	% of Purified Water Recovery	25%, 50 LPH
	% Rejection of TDS	75%
	Operating Temperature	15° C to 45° C
	RO Membrane Flushing	Auto-flush at every start, every stop and every one hour for 1 minute
	RO System & Water Cooler Operating Voltage	180 - 250V
Body	Storage Tank Material	SS 304
	Outer Body Material	SS 304
	Type of Product Construction	Concealed
	Type of Installation	Indoor
Dimensions & Net Weight	Dimensions (W x D x H) mm	660 x 480 x1355
	Net Weight (kg)	73
Refrigerant	Refrigerant	R134a



DESCRIPTION	MODEL TYPE	BWD3TTHA TABLE TOP	BWD3FMCHA FLOOR MOUNTED	BWD3FMRHA FLOOR MOUNTED	BWD3TTEA TABLE TOP	BWD3FMEA FLOOR MOUNTED
Model		Dispenses Hot/ Cold/ Ambient water	Dispenses Hot/ Cold/ Ambient water	Dispenses Hot/ Cold/ Ambient water	Dispenses Hot/ Cold/ Ambient water	Dispenses Hot/ Cold/ Ambient water
Performance Parameters	Display	LED	LED	LED	LED	LED
	Refrigerator Capacity (Ltr.)	N.A.	N.A.	18 Ltr.	N.A.	N.A.
	Voltage / Frequency / Phase	230V / 50Hz / Single	230V / 50Hz / Single	230V / 50Hz / Single	230V / 50Hz / Single	230V / 50Hz / Single
	Cold / Hot Tank Specification	SS 304 Food Grade	SS 304 Food Grade	SS 304 Food Grade	SS 304 Food Grade	SS 304 Food Grade
Features	Storage Capacity (Ltr.)	3.5L	3.5L	3.5L	2.5L	2.5L
	Cooling Capacity (Ltr. / Hour) at 12°C Discharge	2.5 Ltr./ hr	2.5 Ltr./ hr	2.5 Ltr./ hr	2 Ltr./ hr	2 Ltr./ hr
	Power Consumption (Watt) ~ Cooling	140 Watt	140 Watt	140 Watt	120 Watt	120 Watt
	Heating Capacity (Ltr. / Hour) at 83°C Discharge	4.5 Ltr./ hr	4.5 Ltr./ hr	4.5 Ltr./ hr	4 Ltr./ hr	4 Ltr./ hr
	Power Consumption (Watt) ~ Heating	500 Watt	500 Watt	500 Watt	420 Watt	420 Watt
	Drip tray	Yes	Yes	Yes	Yes	Yes
	Faucet Type	Push Type/Child Lock for Hot Tap	Push Type/Child Lock for Hot Tap	Push Type/Child Lock for Hot Tap	Push Type/Child Lock for Hot Tap	Push Type/Child Lock for Hot Tap
	Number of Faucets	3	3	3	3	3
Dimensions & Net Weight & Refrigerant	Dimensions (W x D x H) mm	315 x 365 x 495 mm	315 x 365 x 975 mm	315 x 365 x 975 mm	315 x 330 x 490 mm	310 x 345 x 996 mm
	Net weight (Kg)	13	16	18	11	14
	Refrigerant	R134a	R134a	R134a	R134a	R134a

İcecek

Hazır Yiyecek



RETAIL REFRIGERATION

Blue Star now offers a new, cutting-edge range of models in retail refrigeration. These new models are sustainable, practical, elegant and consumes less power due to their smart design.

With a wall side plug-in, these refrigeration cabinets can be integrated easily into any kind of retail planogram with their compact build. The clear and open design allows customers to choose their products easily.

This range of multi-deck chillers simplifies the retail business on the dairy and vegetable/fruit products front. They also ensure lasting freshness along with low energy bills making Blue Star's Retail Refrigerators ideal for any supermarket.

FEATURES



Small footprint with compact design



Accessible and ergonomic



Fully configurable to different concepts



Easily adaptable to changes of product



Reduces energy consumption with higher evaporation temperature



Low operating costs



Practical fittings designed for simplified installation and maintenance

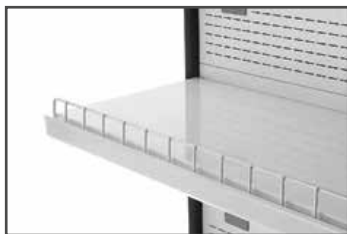

GRID FRONT RISER

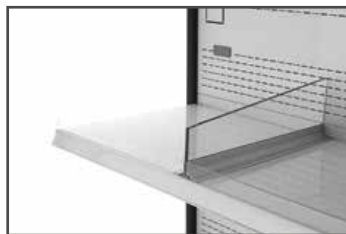

PLEXI SHELF DIVIDER



GRID SHELF DIVIDER



BASIN DIVIDER



CANOPY OR UNDER SHELF
LED LIGHTING



SHELF LIGHTING T5/T8



SLIDING OR HINGED DOOR



FRONT THERMOPANE GLASS



PLEXI FRONT RISER

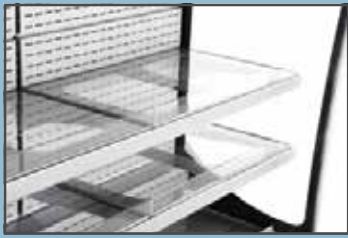

GLASS SHELF

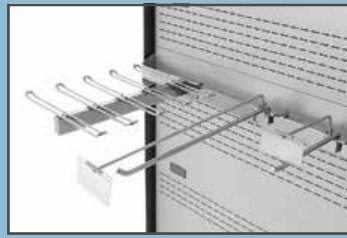

HOOK BAR



SHELF LIGHTING T5/T8

DELICATESSEN

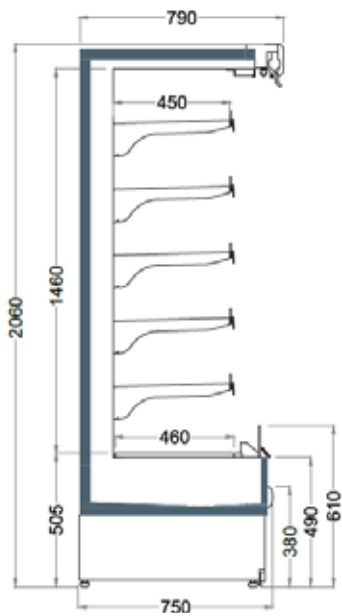

FRUIT & VEGETABLE

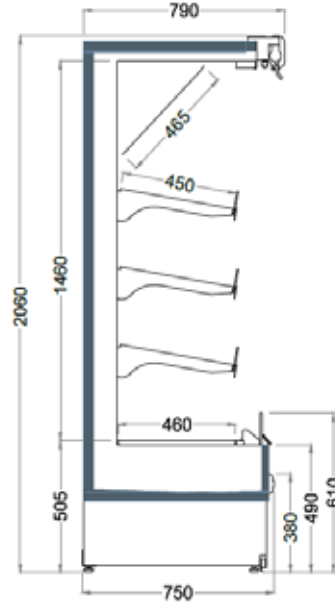

Technical Specifications

	KRYSTA 12C FV/MT/DL	KRYSTA 18C FV/MT/DL	KRYSTA 25C FV/MT/DL
Dimensions	2060 x 1250 x 750	2060 x 1875 x 750	2060 x 2500 x 750
Temperature Range	FV : +4°C to +6°C		
	DL : +2°C to +4°C		
	MT : -1°C to +1°C		
Refrigerant	R134A / R404A / R407F / R449A / R290 / R1270		
Electrical Supply	230V/50Hz/1Ph		
Climate Class	3 (25°C, 60% RH)		
Display Area (m²)	DL : 3.39	DL : 5.08	DL : 6.78
	FV : 2.26	FV : 3.39	FV : 4.53



STORAGE SOLUTIONS

We offer the widest range of freezers to help conserve and transport frozen produce. With a wide range of hard top freezers, we offer solutions to any application with sizes and capacities to meet any and every possible need.

For storage applications which do not require display for the consumer, we offer cost-effective hard-top freezers and bottle coolers. Hard-top freezers are economical yet rugged, reliable and well-suited for storage of typical general store provisions like dairy products and ready-to-cook packets which require freezing. For storing diverse range of products without occupying huge spaces, Blue Star's Cooler-cum-Freezer is ideal. It has a 2-in-1 facility to store frozen and chilled products. Soft-drinks, water bottles, beer etc. need storage in heavy-duty coolers that can cool rapidly despite the constant opening and closing of doors, and Blue Star Bottle Coolers serve that application admirably.

Display-and-Store

In retail applications where high-end product display is essential for better presentation, impulse buying or simply to complement the aesthetics of the interiors, we offer glass-top freezers, Visi Coolers and Visi Freezers and for the premium end of the market, world-class display freezers with stunning looks. Glass-top freezers allow for frozen storage and a view of the products inside, offering a good balance between floor-space and display. Visi Coolers and Visi Freezers are upright refrigeration storages that look good and offer consumers a clear view of stored products, giving you great display to real estate ratio. And our latest launch, a range of Premium Display Freezers, offers you superb looks combined with efficient freezing – an unbeatable combination of the best of art, science and commerce.



The Blue Star Advantage



Storage and/or display in appropriately chilled environment



Space for attractive product branding



Dispensing ease



High performance cooling/freezing



Easy maintenance



Availability of cost-effective genuine spares



Small footprint

Hard-top Deep Freezers

Frozen foods. Dynamic performance.

Deep Freezers are by far the best means to keep your stock fresh for longer durations. At the same time, they help your business perform better. Our range of Hard-top Deep Freezers incorporates cutting-edge technology and innovative features, guaranteeing long-lasting freshness. Built to last and to meet the demands of high sub-continental temperatures, these machines cut power bills through energy-saving innovations, helping your business grow. Just what you would expect from the expert.

FEATURES



Corrosion-resistant body made of pre-coated sheet



Eco-friendly refrigerant (R290)



Twin-door larger capacity models to avoid cooling loss



Locks in all models



High density PUF insulation for better holding time



Highly energy-efficient compressor



Dual tone colour



Recessed handle



Heavy duty casters





Technical Specifications

DESCRIPTION	UNITS	CHFSD100D/ CHFSD100DP	CHFSD150D/ CHFSD150DP	CHF200CP	CHFSD200D/ CHFSD200DP	CHF300B/ CHF300BP	CHFSD300D/ CHFSD300DP	CHF300C
Gross Capacity	Ltr.	102	152	200	212	300	302	300
Temperature Range		-18°C to -22°C						
Power Supply		230V / 50Hz / 1 Ph						
Refrigerant		R134a						
No. of Lids		1						
Inner Cabinet		Stucco Aluminium/PP Liner						Stucco Aluminium
PUF Thickness	mm	65		65		60	65	70
Overall Dimensions (WXDXH)	mm	574X524X845	754X524X845	980X560X825	950X524X845	1000X663X770	1116X604X845	1055X663X770
Net Weight	kg	27	31	38	35	59	41	50
No. of Baskets		1						

DESCRIPTION	UNITS	CHFDD300D/ CHFDD300DP	CHF400HG	CHF500HG	CHF400B	CHF500B	CHFDD700D
Gross Capacity	Ltr.	302	400	470	400	500	750
Temperature Range		-18°C to -22°C					
Power Supply		230V / 50Hz / 1 Ph					
Refrigerant		R134a					
No. of Lids		2					
Inner Cabinet		Stucco Aluminium/ PP Liner	PP Liner		Stucco Aluminium		PP Liner
PUF Thickness	mm	65	60		60		70
Overall Dimensions (WXDXH)	mm	1116X845X604	1440X670X835	1640X670X835	1248X735X855	1546X735X862	1945X825X839
Net Weight	kg	41	65	73	68	73	85
No. of Baskets		1					

Note: Technical specifications are subject to change due to continuous product development.



Cooler-cum-Freezer

Our Cooler-cum-Freezer is ideal for your business. It has a 2-in-1 facility to store frozen and chilled products and allows you to sell a diverse range of products. It saves space as it combines two machines in one. It is also cost-effective as it lowers capital investment and operating costs. And takes good care of your needs and your customers'.



FEATURES

2

Dual compartment machine configured as freezer in one and cooler in the other



Two separate lids ensure independent access to freezer and cooler chambers



Easy to clean and maintain hygiene



Excellent drain design



Versatile wheels for easy movement and placement of unit



Fast freeze mode

Technical Specifications

DESCRIPTION	UNITS	CHFK300A	CHFK500A
Cooler Capacity	Ltr.	137	144
Freezer Capacity	Ltr.	175	297
Temp range - Cooler	°C	2°C to 8°C	2°C to 8°C
Temp range - Freezer	°C	-18°C to -22°C	-18°C to -22°C
Overall Dimensions (WxDxH)	mm	1336 x 680 x 865	1540 x 920 x 850
Net Weight	kg	53	72

Note: Technical specifications are subject to change due to continuous product development.

BOTTLE COOLERS

Quick Cooling for Quick Profits.

Keep your drinks chilled and your clients happy with Bottle Coolers from Blue Star, India's leading air conditioning and refrigeration company. Designed to meet the heavy demands of commercial businesses such as restaurants, hotels, pubs and fast food outlets, these coolers come with heavy-duty compressors that allow bottles to be chilled quickly. Built rugged and ready for operation in Indian conditions, they are the perfect solution for your business.

Why a bottle cooler and not a deep freezer?

During summer, most beverage bottles and cans are delivered warm. To cool such bottles and cans in lesser time, you need a cooler with a heavy duty compressor that has adequate power. Normal deep freezer compressors come with a low capacity, suitable only for pre-frozen ice-creams. Also, the thermostats of these freezers are altered locally. All this makes deep freezers incompetent when it comes to faster and better cooling of beverages, especially in summer.

Why a bottle cooler and not a refrigerator?

Refrigerators are essentially designed for home applications where door openings are few. These refrigerators come with small compressors that are incapable of handling large loads. Furthermore, they cannot maintain low temperatures during long power cuts. Bottle coolers on the other hand have double the capacity and can save up to 50% on the power bill.



FEATURES



Range: 300, 400 & 500 ltrs



Option of PP/SS in a tank



PUF PUF insulation



Low power consumption



Eco-friendly refrigerant



Recessed handle



Tropicalised for tough weather conditions



Double door option available in higher capacities



LONG LIFE Pre-painted sheet for longer life and easy cleaning



Thermostat for accurate temperature control



Technical Specifications

DESCRIPTION	UNITS	CHBK300A	CHBK300SSB	CHBK400A	CHBK400SSB	CHBK500A	CHBK500SSB
Gross Capacity	Ltr.	291	291	400	400	470	470
Temperature Range		2°C to 8°C					
Power Supply		230V / Single Phase / 50Hz					
Refrigerant		R134a					
No. of Lids		2					
Inner Cabinet		Pre-coated GI Sheet	SS 304	Pre-coated GI Sheet	SS 304	Pre-coated GI Sheet	SS 304
PUF Thickness	mm	60					
Overall Dimensions (WXDXH)	mm	1140X620X850	1140X620X850	1440X620X850	1440X620X850	1640X620X850	1640X620X850
Net Weight	kg	55	55	65	65	73	73
Wheels/Legs		Heavy Duty Casters					

Note: Technical specifications are subject to change due to continuous product development.



Freezer on Wheels

Blue Star now offers a FOW - Freezer on Wheels. Based on the Powercool Technology, the FOW is ideal for temperature holding and the storage of ice cream cups, candies and the ever popular 'kulfi' as well as any other varieties of ice creams. With its long-lasting cooling and hassle-free usage, great business is guaranteed every day.



FEATURES



Long lasting cooling



Lower energy consumption



Efficient and sturdy compressor



Thick PUF Insulation



Tropicalised for Indian condition



Technical Specifications

Type	Eutectic Freezer on Wheels
Gross Volume (L)	115
Net Weight (Kg)	104
Temperature Range	-26°C @ 43°C Ambient
Temperature Holding Time (-26°C to -18°C)	8 hours
Overall Dimensions (mm)	975 x 640 x 705
Insulation Material	PUF
Insulation Thickness (mm)	65
Temperature Holding Media	Glycol
No of Lids	1
Material	Stainless Steel
Refrigerant	R134a

Display-and-Store Solutions

Visi Coolers and Visi Freezers

Our Visi Coolers and Visi Freezers are the smartest and easiest ways to preserve and display your products at the same time. The vertical storage Visi Coolers and Visi Freezers are specially designed to cool the products uniformly. The illuminated canopy can be customised to suit your branding needs. So while display increases product visibility, visibility increases sales and profits.



FEATURES



Tropicalised for harsh Indian summers



Adjustable shelves



UV-protected galvanised sheets for interiors and exteriors



Energy efficient cooling unit



Eco-friendly refrigerant



Self-closing door with locking facility



Clear product visibility with reflective glass



Uniform cooling



Back-lit canopy option for merchandising



Technical Specifications

Model		Visi Cooler					
Description	Unit	VC125D	VC175D	VC225D	VC275D	VC325D	VC555D
Gross Capacity	L	130	170	220	250	300	530
Temperature		+2°C to +8°C	+2°C to +8°C	+2°C to +8°C	+2°C to +8°C	+2°C to +8°C	+2°C to +8°C
Power Supply		230V/1Ph/50Hz	230V/1Ph/50Hz	230V/1Ph/50Hz	230V/1Ph/50Hz	230V/1Ph/50Hz	230V/1Ph/50Hz
Refrigerant		R600	R600	R600	R600	R600	R290
No. of Doors	No.	1	1	1	1	1	2
Provision for Locking		Available					
Overall Dimensions (including hinge, caster etc)	mm	495 x 515 x 1160	495 x 515 x 1280	535 x 520 x 1735	575 x 600 x 1705	615 x 610 x 1790	1000 x 580 x 1855
Net Weight	kg	44	46	61	61	64	115
No. of Shelves	No.	-	Wire/4	Wire/4	Wire/4	Wire/4	-

Model		Visi Cooler			Visi Freezer
Description	Unit	VC375E	VC690E	VC1200E	VF375E / VF375F*
Gross Capacity	L	372	657	945	300
Temperature		1°C to 10°C			-12°C to -22°C
Power Supply		230V / Single Phase / 50Hz			230V/1Ph/50Hz
Refrigerant		R134a			R404a
No. of Doors	No.	1	1	2	1
Provision for Locking		Available			Available
Overall Dimensions (including hinge, caster etc)	mm	595 x 640 x 1980	780 x 705 x 2080	1200 x 742 x 2000	595 x 640 x 1965
Net Weight	kg	81	123	164	96
No. of Shelves	No.	5			6

*LED light option available in VF375F model only.

Technical specifications are subject to change due to continuous product development.

Glass-top Deep Freezers

Frozen foods. Attractive display.

Our Deep Freezers are also available with glass-top sliding doors. They offer you economical freezing, storage and display solutions, ideal for smaller outlets which need both refrigeration and display. Products such as frozen fruits, ready-to-eat foods, ice-cream packs, etc. benefit from visibility which leads to impulse purchases.



Along with the features already listed earlier under Hard-top Deep Freezers, the Glass-top Freezer offers low-emission imported glass sliding doors on the top. Their better insulation properties also help in increasing hold-time. And the easy-slide glass doors make it convenient for a customer to make a choice personally.





Technical Specifications

Description	Units	GTO110B	GT200AG	GT300AG	GT400AG	GT500AG
Gross Capacity	L	110	194	300	388	502
Temperature Range		-18°C to -22°C				
Power Supply		230V / Single Phase / 50 Hz				
Refrigerant		R134a	R290			
No. of Lids		1	2			
Glass Type		Low Emissive Toughened Glass				
Inner Cabinet		Anodised Stucco Aluminium				
PUF Thickness	mm	65				
Overall Dimensions (W x D x H)	mm	635x585x845	960x525x810	1005x670x889	1235x670x889	1515x670x889
Net Weight	kg	33	38	55	65	73
No. of Baskets		1		2	4	4
Wheels/Legs		Heavy Duty Lockable Casters				

Note: Technical specifications are subject to change due to continuous product development.



PREMIUM DISPLAY FREEZERS

Stunning looks. Superior performance.

Our range of premium display freezers is stunning in looks and superior in performance. The gorgeous and streamlined body is ideal for cooling and display of ice creams and frozen foods.





These premium display freezers are designed to have a small footprint so that they occupy less space. Widely used in departmental stores, parlors and eateries, a choice of premium models allow you to choose what is most suited to the economics of your business. The sides can be custom-branded to suit any particular company or product.

Technical Specifications

Description	PDF200AG	PDF250AG	PDF300AG	PDF200A	PDF250A	PDF300A	PDF400E	PDF500E
Gross Capacity (L)	182	282	328	182	282	328	442	541
Temperature Range	-18°C to -22°C							
Power Supply	230V / Single Phase / 50 Hz							
Refrigerant	R290			R134a			R404a	
No. of Lids	2							
Glass Type	Low Emissive Toughened Glass							
Inner Cabinet	Anodised Stucco Aluminium							
PUF Thickness (mm)	70 mm							
Overall Dimensions (W x D x H) mm	756 x 656 x 894	986 x 656 x 928	1224 x 624 x 935	750 x 650 x 833	986 x 656 x 925	1224 x 624 x 810	1320 x 650 x 888	1570 x 650 x 888
Net Weight (Kg)	47	56	70	50	56	70	72	110
No. of Baskets	2	3	4	End To End Baskets			4	5
Wheels/Legs	Heavy Duty Lockable Casters							

Note: Technical specifications are subject to change due to continuous product development.



Double-Decker Display Freezer

Our latest product offering is the new Double Decker Display Freezer. It creatively blends pieces of art to display merchandise uniquely. These display freezers are ideal for storage of impulse purchase products such as ice creams and popsicles. Innovatively built, it is suitable for air conditioned stores and rugged Indian conditions.

It is built to adapt to a smaller footprint and designed to increase your sales by ensuring a larger display of your products. Suitable for showcasing and retailing ice creams and frozen foods, it is ideal for middle and large-sized supermarkets.

FEATURES



Tropicalised for harsh Indian summers



Ergonomic handles



Panoramic view of the merchandise



Quick freezing



Sleek and gorgeous looks



Strong wheels for easy movement



CFC free



Efficient and high-performance compressor



Lock facility available



Low noise operation

Technical Specifications

DESCRIPTION	UNITS	DDF420E
Gross Capacity	Ltr.	242
Temperature Range		-12°C to -22°C
Power Supply		230V / Single Phase / 50Hz
Refrigerant		R404a
Glass Type		Low Emissive Toughened Glass
Inner Cabinet		Anodised Stucco Aluminium
Insulation Material		PUF Insulation
Input Power	W	400
Overall Dimensions (WDXH)	mm	1570 X 650 X 888
Wheels/Legs		Heavy Duty Lockable Casters



Note: Technical specifications are subject to change due to continuous product development.

Works for nature.
Works for you.



ECO-FRIENDLY GREEN PANELS WITH CYCLOPENTANE PUF INSULATION

Blue Star is known for its innovation and technological leadership and has introduced many cutting-edge products and solutions which offer higher efficiency, better performance and more reliability—factors that matter most to the customer, especially in the international marketplace.

We also ensure that every new solution we bring out is eco-friendly, helps to reduce global warming, has zero ozone depletion properties and contributes to a sustainable future. The introduction of the eco-friendly R410a refrigerant in most of our air conditioning solutions, for example, goes a long way in helping the country meet its obligations to reduce the use of HFCs under the Montreal Protocol.

We now introduce eco-friendly pre-fabricated insulation panel systems in a range of profiles, thicknesses, and finishes. The speciality of these panels is that they are perfect for the speedy creation of cold stores of any size at the site due to their precise interlocking design and great insulation properties. They are also eco-friendly both in their material and in their manufacturing process itself.

These new eco-friendly panel solutions can be used to create cold storages of any size, from small walk-ins to very large cold rooms.

The Perfect Cold Room

Cold storage is a critical piece of infrastructure for any industry. The quality of stored produce and raw materials depends on the reliable and precise functioning of the cold storage.

Our experience in creating cold storages that offer different storage conditions in terms of temperature, humidity, fresh air, air flow etc. to suit different industry requirements has made us the leaders in this domain as well.

Our engineers plan and design cold rooms based on advanced heat load calculations using internationally acclaimed software and build your cold rooms with great precision.



Blue Star's Cold Storage Division's domain expertise extends to a wide spectrum of industries that includes:

FMCG	Food Processing	Research & Development Labs
Floriculture	Meat Processing	Healthcare
Horticulture	Fisheries	Mortuaries
Agro Industry	Pharmaceuticals	Cold Chains
Hotels & Restaurants	Ripening Chambers	Auto Industry



Pre-fabricated from Blue Star

Panels

Our new range of pre-fabricated insulation panel systems come with easy-to-use interlocking panels that can be used to create cold rooms of any size at the site.

Since the insulation material in these panels is foamed between two metal skins, they offer highly effective insulation for cold rooms.

What's more, these panels are designed to ensure precision interlocking and hence they form leak-free walls ideal for cold rooms.

Manufactured in a wide range of profiles, thicknesses and finishes, these systems can be used to create cold stores at the site and of any size – from small walk-ins to very large cold rooms.



Doors

We offer a complete range of insulated doors to complement the world-class environment friendly PUF panels.

The polyurethane foam insulation sandwiched between the GI sheets makes the doors perfect for high- performance cold rooms.

- **Self-closing:** Ensures that the door remains closed without any human interaction.
- **Safety release:** Doors can be opened from the inside.
- **View port:** Helps view products stored inside without opening the door, which is not just for convenience but for power saving too.
- **Posi seal:** Provides perfect alignment of frames and ensures perfect closing movement.
- **Sweep gasket:** Air-tight heavy-duty sealing gasket below the door remains flexible at any temperature.
- **Thermal break:** Eliminates thermal conductivity which otherwise leads to condensation and ice formation.

An Eco-friendly DNA

Our new range of pre-fabricated insulation panels are eco-friendly from the ground-up since even the manufacturing process is green.

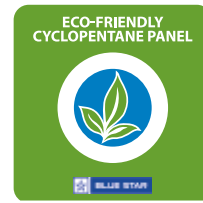

Panel systems

Cyclopentane: The eco-friendly blowing agent

Cyclopentane is increasingly becoming an industry standard the world over as an eco-friendly blowing agent. We also use cyclopentane as the blowing agent in the manufacture of our new series of insulation panels. This makes the panels 'green' even in their manufacturing process, and further underlines our commitment to a greener tomorrow.

This ensures zero Ozone Depleting Potential (ODP) and reduces Global Warming Potential (GWP) as compared to the more generally used HCFC-141b which is not eco-friendly.

Why Cyclopentane

ODP (Ozone Depletion potential): 0

GWP (Global Warming Potential): Negligible (11)

Complies with TUV standards, CCOE (India) certification

Our commitment to a healthy environment is further reinforced by our investment in a cyclopentane process. This not only ensures superior yet environmentally friendly products but also supports India's obligations under the Montreal Protocol on 'Substances that Deplete the Ozone Layer'.



Cyclopentane vs Conventional HCFC-141b :

Sr. No.	PARTICULARS	HCFC 141b	CYCLOPENTANE
1	Density (kg/m ³)	35-37	37-40
2	Compressive Strength (kg/cm ²)	1.5-1.8	1.6-1.9
3	Closed Cell Content (%)	> 90	> 90
4	K-value (w/m oK)	0.0195	0.022
5	GWP (Global Warming Potential)	630	11
6	ODP (Ozone Depletion Potential)	0.1	0
7	Fire Retardant Property	Self-extinguishing	Self-extinguishing

CFC and HCFC-free Polyurethane

The insulation material used within our new range of pre-fab panel systems is also eco-friendly, being made of CFC/HCFC-free polyurethane.

This is in accordance with India's obligations under the Montreal Protocol on 'Substances that Deplete the Ozone Layer', which the 'Ozone Cell' (specially created within the Ministry of Environment, Govt of India) is spearheading under the 'HCFC Phase Out Management Plan (HPMP) Stage 1B'.

Facilities aiming to become green buildings will find these panels ideal for their LEED certification process.



Precision Locking Mechanism

Each Blue Star pre-fabricated insulation panel has cam-action locking devices precisely positioned and firmly anchored within it. All cam-locks have integral rear flanges to permanently anchor their position during the manufacture of the PUF panels. Cam-locks are also placed at exact matching locations on the tongue and groove side to ensure perfect locking.

All cam-locks are accessible from the inside by means of a hex wrench furnished with the panels. Access ports for cam-locks are covered with snap-in cap plugs that must be snapped out before accessing the cam-locks thus making them tamper-proof.

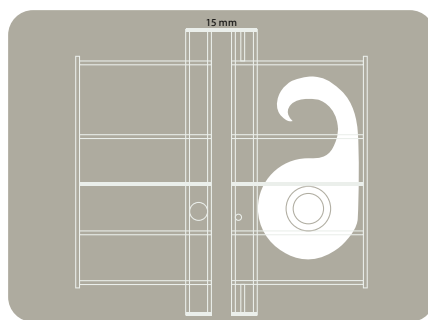

BEFORE LOCKING THE PANEL

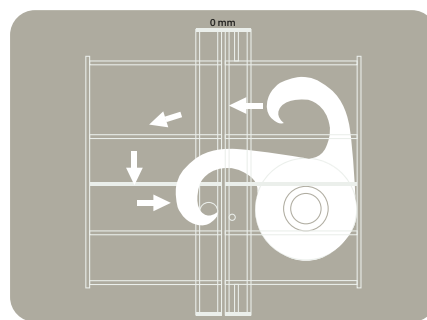

AFTER LOCKING THE PANEL



Technical Specifications

SR. NO.	DESCRIPTION	GENERAL SPECIFICATIONS
1	PUF Panel Thickness	40/60/80/100/127mm
2	PUF Panel Cover	PP or SS
3	Sheet Metal Thickness	0.4/0.5mm
4	Temperature Range	-30°C to +80°C
5	PUF Blowing Agent	Cyclopentane (C5) - (CFC & HCFC free)
6	Lock Arrangement	Cam-Lock with metal plunger
7	PUF Density	40kg/m ³
8	Panel Length	Any lengths up to 14m on request
9	Panel Width	11.5/23/34.5/46 inches
10	Panel Joint	Tongue & Groove joint
11	Panel to Panel Fitment	The gap between two fitted panels < 3 mm





FEATURES AND BENEFITS



PUF insulation core ensures excellent K factor



High density polyurethane offers better strength



Perfect joints eliminate air leakages



Effective thermal insulation results in negligible thermal conductivity



Suitable for a wide temperature range of -30°C to +80°C



In case of fire, stops burning when source of fire is removed



Occupies less space due to efficient insulation



Uses eco-friendly blowing agent cyclopentane



Modular construction resulting in faster installation



Easily expandable to larger sizes



Available in stainless steel and pre-painted GI



Thickness range from 40mm to 127mm



90° corner panels to ensure stability

Wide Range of Refrigeration Units

We offer a wide range of both evaporating and condensing units. It includes both air-cooled and water-cooled condensers with technology from world leaders.

Depending on the application, different temperature zones need to be maintained:

Low (-23°C to -5°C),

Medium (-5°C to +2°C),

High (+2°C to +15°C)

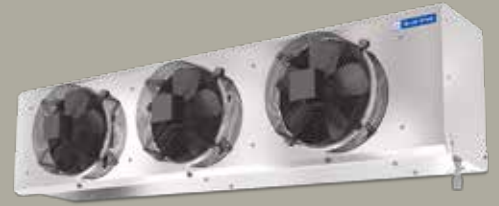

Evaporating units

Our evaporating units are compact, slim and sleek; so they occupy minimum space ensuring maximum storage space. Other features include:

SS

Stainless steel body and excellent corrosion resistance



Inner grooved copper tubes for superior heat transfer



In-built defrost heaters for low-temperature units



External rotor driven fans with low noise levels



Removable side panels for easy service



Drain on the same side of refrigeration to avoid making multiple openings in the PUF panels



Condensing Units

These units are characterised by high-efficiency heat transfer and low power consumption. Other features include:



Energy-efficient scroll and reciprocating compressors



UV and corrosion resistance



Filter drier for moisture and dirt protection



Pre-charged unit with service valves



In-built safety and control devices



Weather-proof polyester powder coated canopy



Microprocessor Controller and Power Panel

Our refrigeration units come with intelligent microprocessor-powered controllers which are BMS compatible and HACCP provisioned (available in select models).

- Ready-to-use power panels which make electrical connections simple, safe, fast and long-lasting. They are available with every refrigeration unit.
- Powder-coated weather proof housing
- Protection against common electrical failures
- Interlock of safety features



Perfect Installations

Without carefully executed installations, the efficiency and reliability of a cold room can be compromised. Our engineers are equipped with the latest technology and knowledge which enables them in carrying out precise installations. Example checks considered by them are:

- The location of the evaporator within the cold room for uniform cooling and air distribution
- Level flooring (0-0 level) to avoid misalignment of walls
- Proper selection of copper parts and pipe sizes
- Minimising bends and unduly long runs



NOBODY COOLS BETTER™

For more information, please contact **BLUE STAR LIMITED** - **Ahmedabad**: 301 & 302, (3rd floor), Abhishree Avenue, (Near) Nehru Circle, SM Road, Ambawadi, Ahmedabad - 380015. Tel: (079) 40224000 • **Bengaluru**: Anjuman Kay A R R Tower, No 28, Ward No 77, Mission Road, Bengaluru - 560027. Tel: +91 (80) 4185 4000 • **Bhubaneswar**: 3A Satya Nagar, 2nd floor, Bhubaneswar - 751007. Tel: (0674) 2572403/2573670 • **Chandigarh**: 4th floor, Adarsh Mall, Plot No. 50, Industrial & Business Park, Phase II, Chandigarh - 160002. Tel: (0172) 5024000 • **Chennai**: KRM Plaza, No. 2, Harrington Road, Chetpet, Chennai - 600031. Tel: (044) 42444000 • **Ghaziabad**: C 53A, Third floor, Rajnagar District Centre (RDC), Raj Nagar, Ghaziabad - 201001, Uttar Pradesh. Tel: (0120) 2821400 • **Goa**: 210, 2nd floor, Gera's Imperium 1, Patto, Panjim, Goa - 403001. Tel: (0832) 2438171/2437287 • **Guwahati**: Oasis Plaza, 1st Floor, Dr. B. Baroah Road, Ulubari Kamrup, Guwahati - 781007. Tel: (0361) 2468496 • **Gurugram**: 6th floor, Vatika Atrium, Golf Course Road, Sector 53, Gurugram - 122002. (Haryana). Tel: (0124) 4094000 • **Indore**: Office No. 502, Maloo-01 26/C, Scheme No. 94/C Ring Road, Indore - 452010. Tel: (91) (731) 4001211/4001311 • **Jaipur**: A-19, 1st floor, Main Sahakar Path, Near Sahakar Bhavan, Jaipur - 302001. Tel: (0141) 2744033-35 • **Jamshedpur**: 2nd Floor, Sai Apartment, Opposite Thakur Pyara Singh Ground, Kasidhi, Sakchi, Jamshedpur - 831 001 Tel: (91) (657) 222 1530 • **Kochi**: 2nd floor Millennium Plaza, MKK Nair Road, Alinchuvadu Junction, Kochi - 682024. Tel: (0484) 4499000 • **Kolkata**: 7, Hare Street, Kolkata - 700001. Tel: (033) 22134100 • **Ludhiana**: SCO 16-17, Feroze Gandhi Market, Fortune Chambers, 3rd floor, Ludhiana - 141001. (Punjab) Tel: (0161) 5001404 • **Lucknow**: 177/4, Faizabad Road, Lucknow - 226007 Tel: (0522) 403400 • **Mumbai**: Blue Star House, 9-A Ghatkopar Link Road, Saki Naka, Mumbai - 400072. Tel: (022) 6684100 • **Nagpur**: 219, Bajaj Nagar, 1st floor, South Ambazari Road, Nagpur - 440010. Tel: (0712) 2249000/6624000 • **New Delhi**: Blue Star Ltd., Plot No. 8, 1st Floor, Elegance Tower, Jasola, New Delhi - 110025 • **Patna**: Ambition Business Centre, Laxmikant Niketan Parisar, 4th floor, 'B' Block, Room No. 405, Jamal Road, Patna - 800001 • **Pune**: 201/A, Nityanand Complex, 1st floor, 247/A, Bund Garden Road, Pune - 411001. Tel: (020) 41044000/26169332 • **Raipur**: Alaska Corporates, 3rd floor, Opp. VIP Road, Jivan Vihar Colony, G E Road, Raipur, Chhattisgarh - 492006. Tel: (0771) 6544000 • **Hyderabad**: Ashoka Raghupati Chambers, No. 1-10-60 to 64, 4th Floor, S P Road, Begumpet, Hyderabad, Telangana - 500 016. Tel: (040) 4400 4000 • **Thane**: 2nd Pokhran Road, Majiwada, Thane - 400601 Tel: (022) 6715 4500 • **Thiruvananthapuram**: TC IV/962, 'Chandrika', Sree Chitra Nagar, PipeLine Road, Kawdiar, Thiruvananthapuram - 695003. Tel (0471) 2720025/65 • **Vadodara**: Ramakrishna Chambers, 7th floor, Productivity Road, Alkapuri, Vadodara - 390007. Tel: (0265) 2330334/6614100 • **Visakhapatnam**: D. No. 49-24-65/1, Near Sankarmatam Road, Madhura Nagar, Visakhapatnam - 530016. Tel: (0891) 2748405/2748433 • **Vijayawada**: No. 40-1-62, Nagas Hafeez Plaza, Opposite to grand modern supermarket, Near BENZ Circle, M G Road, Vijayawada 10. Tel: (0866) 2484004