

**SUPER
MARKET
REFRIGERATION**

REFRIGERATION SOLUTIONS TO HELP
YOUR BUSINESS DO BETTER.



Scan QR Code -
Blue Star Customer
Care Mobile App



SMS "SERVICE" to 57575



Download Blue Star Customer
Care Mobile App from
App Store & Google Play



To know more about Blue Star, visit
www.bluestarindia.com, email us at
coolingsolutions@bluestarindia.com
or SMS 'COOL' to 57575



24X7 CUSTOMER CARE
(Toll Free) 1800 209 1177
1860 266 6666

For more information, please contact **BLUE STAR LIMITED - Ahmedabad:** 301 & 302, (3rd floor), Abhishree Avenue, (Near) Nehru Circle, SM Road, Ambawadi, Ahmedabad - 380015. Tel: (079) 40224000 • **Bengaluru:** Anjuman Kay A R R Tower, No 28, Ward No 77, Mission Road, Bengaluru - 560027. Tel: +91 (80) 4185 4000 • **Bhubaneshwar:** 3A Satya Nagar, 2nd floor, Bhubaneshwar - 751007. Tel: (0674) 2572403/2573670 • **Chandigarh:** 4th floor, Adarsh Mall, Plot No. 50, Industrial & Business Park, Phase II, Chandigarh - 160002. Tel: (0172) 5024000 • **Chennai:** KRM Plaza, No. 2, Harrington Road, Chetpet, Chennai - 600031. Tel: (044) 42444000 • **Ghaziabad:** C 53A, Third floor, Rajnagar District Centre (RDC), Raj Nagar, Ghaziabad - 201001, Uttar Pradesh. Tel: (0120) 2821400 • **Goa:** 210, 2nd floor, Gera's Imperium 1, Patto, Panjim, Goa - 403001. Tel: (0832) 2438171/2437287 • **Guwahati:** Oasis Plaza, 1st Floor, Dr. B. Baroah Road, Ulubari Kamrup, Guwahati - 781007. Tel: (0361) 2468496 • **Gurugram:** 6th floor, Vatika Atrium, Golf Course Road, Sector 53, Gurugram - 122002. (Haryana). Tel: (0124) 4094000 • **Indore:** Office No. 502, Maloo-01 26/C, Scheme No. 94/C Ring Road, Indore - 452010. Tel: (91) (731) 4001211/4001311 • **Jaipur:** A-19, 1st floor, Main Sahakar Path, Near Sahakar Bhavan, Jaipur - 302001. Tel: (0141) 2744033-35 • **Jamshedpur:** 2nd Floor, Sai Apartment, Opposite Thakur Pyara Singh Ground, Kasidhi, Sakchi, Jamshedpur - 831 001 Tel: (91) (657) 222 1530 • **Kochi:** 2nd floor Millennium Plaza, MKK Nair Road, Alinchuvadu Junction, Kochi - 682024. Tel: (0484) 4499000 • **Kolkata:** Blue Star Limited, Eco Centre Business Tower, 11th Floor, Unit No. : 1&2, Plot No. 4, EM Block, Sector 5, Salt Lake, Bidhannagar - 700091 Tel : (033) 40815400 • **Ludhiana:** Blue Star Limited, 5th Floor Sandhu Tower-2, Gurdev Nagar Ferozpur Road, Ludhiana - 141001 Tel: (91) (0161) 5064000 • **Lucknow:** 177/4, Faizabad Road, Lucknow - 226007 Tel: (0522) 403400 • **Mumbai:** Blue Star House, 9-A Ghatkopar Link Road, Saki Naka, Mumbai - 400072. Tel: (022) 66684100 • **Nagpur:** 219, Bajaj Nagar, 1st floor, South Ambazari Road, Nagpur - 440010. Tel: (0712) 2249000/6624000 • **New Delhi:** Blue Star Ltd., Plot No. 8, 1st Floor, Elegance Tower, Jasola, New Delhi - 110025 • **Patna:** Ambition Business Centre, Laxmikant Niketan Parisar, 4th floor, 'B' Block, Room No. 405, Jamal Road, Patna - 800001 • **Pune:** 201/A, Nityanand Complex, 1st floor, 247/A, Bund Garden Road, Pune - 411001. Tel: (020) 41044000/26161342 • **Raipur:** Alaska Corporates, 3rd floor, Opp. VIP Road, Jivan Vihar Colony, G E Road, Raipur, Chhattisgarh - 492006. Tel: (0771) 4280900 • **Hyderabad:** Ashoka Raghupati Chambers, No. 1-10-60 to 64, 4th Floor, S P Road, Begumpet, Hyderabad, Telangana - 500 016. Tel: (040) 4400 4000 • **Thane:** 2nd Pokhran Road, Majiwada, Thane - 400610 Tel: (022) 6715 4500 • **Thiruvananthapuram:** TC IV/962, 'Chandrika', Sree Chitra Nagar, Pipeline Road, Kawdiar, Thiruvananthapuram - 695003. Tel (0471) 2720025/65 • **Vadodara:** Ramakrishna Chambers, 7th floor, Productivity Road, Alkapuri, Vadodara - 390007. Tel: (0265) 2330334/6614100 • **Visakhapatnam:** D. No. 49-24-65/1, Near Sankarmatam Road, Madhura Nagar, Visakhapatnam - 530016. Tel: (0891) 2748405/2748433 • **Vijayawada:** No. 40-1-62, Nagas Hafeez Plaza, Opposite to grand modern supermarket, Near BENZ Circle, M G Road, Vijayawada 10. Tel: (0866) 2484004



Blue Star products comply with RoHS regulations as per E-Waste (Management & Handling) Rules, 2016. For disposal of E Waste, kindly visit our website www.bluestarindia.com or call our customer care 1800 209 1177 (Toll Free) or 1860 266 6666.



SUPERMARKET REFRIGERATION

Blue Star now offers a new, cutting-edge range of models in supermarket refrigeration. These new models are sustainable, practical, elegant and consumes less power due to their smart design.



The range of Open Chillers and Freezers is designed aesthetically as well as with the use of path-breaking technology for strong operations, preserving the freshness of foods, while maximizing display area for products stored.



Owing to a compact build and wall-side plug-in, Multi-deck Refrigeration Cabinets can be installed into any store format-existing or planned. An open design allows excellent viewing and easy picking for consumers, whilst maintaining long-lasting freshness at low energy consumption rates making shelving easy for dairy, vegetables and fruits.



Created to ensure maximum display area, the Cake Showcase comes in two designs – curved and squared – with an optional marble base, and technology that avoids frost formation.



The uniquely designed Pyramid Chillers, with optional mirror side panels, provide uninterrupted cooling.



The Display Counter design, that comes with a slide glass canopy, gives frozen foods like fish and meat a wider display area while the food grade steel interiors preserve food material for lengthy periods of time.

MULTIDECK CHILLERS - KRYSTA



FEATURES

-  Small footprint with compact design
-  Accessible and ergonomic
-  Fully configurable to different concepts
-  Easily adaptable to changes of product
-  Reduces energy consumption with higher evaporation temperature
-  Low operating costs
-  Practical fittings designed for simplified installation and maintenance
-  Eco-friendly refrigerant

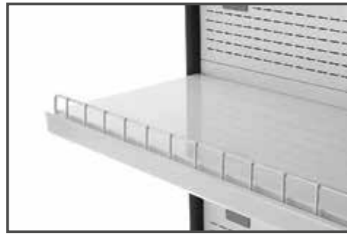

GRID FRONT RISER



PLEXI SHELF DIVIDER

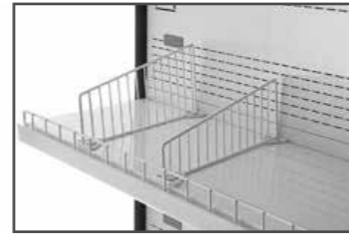

GRID SHELF DIVIDER



BASIN DIVIDER



CANOPY OR UNDER-SHELF LED LIGHTING



SHELF LIGHTING T5/T8



SLIDING OR HINGED DOOR

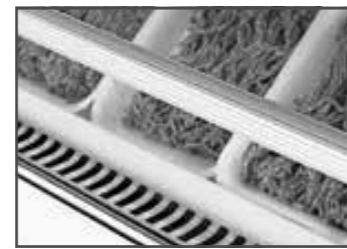

FRONT THERMOPANE GLASS



PLEXI FRONT RISER

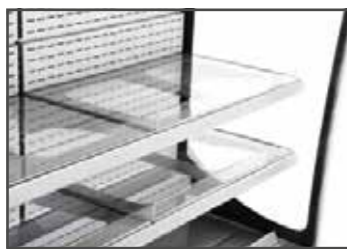

GLASS SHELF

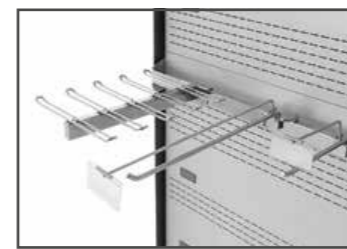

HOOK BAR



SHELF LIGHTING T5/T8

DELICATESSEN

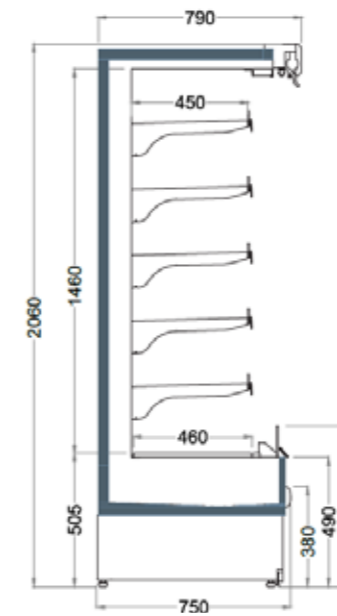

FRUIT & VEGETABLE

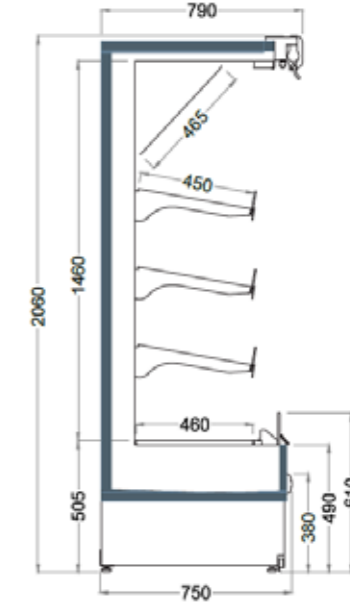

Technical Specifications

	KRYSTA 12C FV/MT/DL	KRYSTA 18C FV/MT/DL	KRYSTA 25C FV/MT/DL
Dimensions (W x D x H) in mm	2060 x 1250 x 750	2060 x 1875 x 750	2060 x 2500 x 750
Temperature Range	FV: +4°C to +6°C		
	DL: +2°C to +4°C		
	MT: -1°C to +1°C		
Refrigerant	R134A / R404A / R407F / R449A / R290 / R1270		
Electrical Supply	230V/50Hz/1Ph		
Climate Class	3 (25°C, 60% RH)		
Display Area (m ²)	DL: 3.39	DL: 5.08	DL: 6.78
	FV: 2.26	FV: 3.39	FV: 4.53



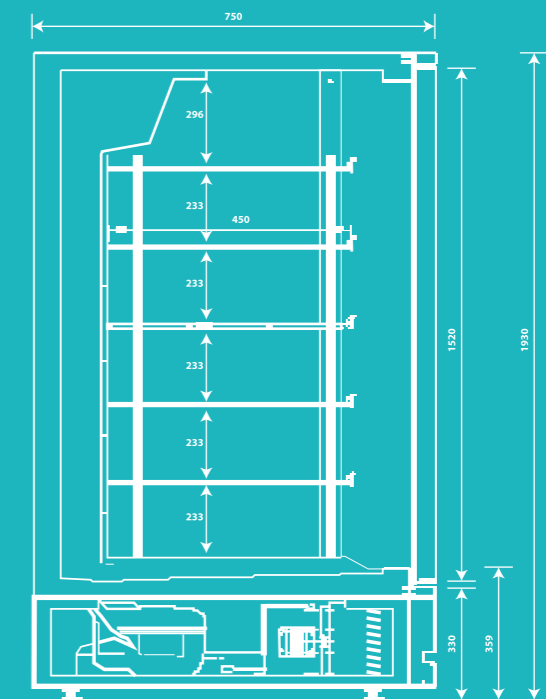

OPEN CHILLERS-KORAL

FEATURES



Large flexible display area



Double tempered & low emissivity glass



Price holders Flaps on shelf



Keeps delicate fruit and dairy fresh



Electronic temperature control with digital display



Available in different sizes in ft : 3, 4, 6, 8



Designed for modular configuration



Energy saving night blind



Low operation cost and maintenance



4 adjustable white prepainted galvanized steel shelves

TECHNICAL SPECIFICATION

MODEL NUMBER	KORAL10CFV/DL/MT	KORAL12CFV/DL/MT	KORAL18CFV/DL/MT	KORAL25CFV/DL/MT
Function	Chiller	Chiller	Chiller	Chiller
Size in ft	3.28	4.28	6.32	8.35
Temp Range °C	1°C To 10°C	1°C To 10°C	1°C To 10°C	1°C To 10°C
Voltage/Frequency	220~240/50 1 Phase	220~240/50 1 Phase	220~240/50 1 Phase	220~240/50 1 Phase
Refrigerant	R404a	R404a	R404a	R404a
Condensor Type	Copper	Copper	Copper	Copper
Evaporator Type	Copper + Fins	Copper + Fins	Copper + Fins	Copper + Fins
Features				
Price Ticket Strip	Yes	Yes	Yes	Yes
Night Blind	Yes	Yes	Yes	Yes
Shelf	4 Shelves	4 Shelves	4 Shelves	4 Shelves
Side Panel	Tempered Glass	Tempered Glass	Tempered Glass	Tempered Glass
Light	Yes	Yes	Yes	Yes
Temp Display	Digital	Digital	Digital	Digital
Colour Option	Multiple	Multiple	Multiple	Multiple
Product Dimension (W x D x H) in mm	985 X 750 X 1930	1285 X 750 X 1930	1895 X 750 X 1930	2505 X 750 X 1930
Packaging Dimension (W x D x H) in mm	1080 X 850 X 2120	1385 X 850 X 2120	1995 X 850 X 2120	2605 X 850 X 2120
Weight in kg	180	210	310	395
Gross Weight in kg	208	242	355	450

SERVE OVER-KORAL



FEATURES

- 

Uniform cooling across the display area



Adjustable temperature setting for assorted products
- 

Interior LED lighting





Available in different sizes in ft : 4, 6, 8 & 12
- 

Electronic temperature display



Consume less energy
- 

Inner cabinet made of food grade steel
- 

Automatic defrost
- 

Double tempered & low emissivity glass

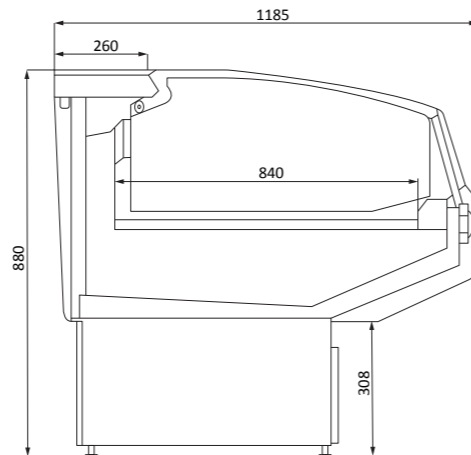

TECHNICAL SPECIFICATION

MODEL NUMBER	KORAL12CSEP	KORAL18CSEP	KORAL24CSEP	KORAL36CSEP	KORAL12CSECP	KORAL18CSECP	KORAL24CSECP	KORAL36CSECP
Function	Chiller	Chiller	Chiller	Chiller	Chiller	Chiller	Chiller	Chiller
Size in ft	4.5	6.5	8.6	12.8	4.5	6.5	8.6	12.8
Temp Range °C	-1°~5°C	-1°~5°C	-1°~5°C	-1°~5°C	-1°~5°C	-1°~5°C	-1°~5°C	-1°~5°C
Voltage/Frequency	220VAC~240VAC 50Hz	220VAC~240VAC 50Hz	220VAC~240VAC 50Hz	220VAC~240VAC 50Hz	220VAC~240VAC 50Hz	220VAC~240VAC 50Hz	220VAC~240VAC 50Hz	220VAC~240VAC 50Hz
Refrigerant	R404a	R404a	R404a	R404a	R404a	R404a	R404a	R404a
Condensor Type	Copper	Copper	Copper	Copper	Copper	Copper	Copper	Copper
Evaporator Type	Copper + Fins	Copper + Fins	Copper + Fins	Copper + Fins	Copper + Fins	Copper + Fins	Copper + Fins	Copper + Fins
Features								
Side Panel	Tempered Glass	Tempered Glass	Tempered Glass	Tempered Glass	Yes	Yes	Yes	Yes
Light	Yes	Yes	Yes	Yes	4Nos	4Nos	4Nos	4Nos
Glass Canopy	No	No	No	No	Tempered Glass	Tempered Glass	Tempered Glass	Tempered Glass
Glass Support	No	No	No	No	Yes	Yes	Yes	Yes
Temp Display	Digital	Digital	Digital	Digital	Digital	Digital	Digital	Digital
Colour Option	Multiple	Multiple	Multiple	Multiple	Multiple	Multiple	Multiple	Multiple
Product Dimension (W x D x H) in mm	1350 X 185 X 880	1975 X 1185 X 880	2600 X 1185 X 880	3850 X 1185 X 880	1350 X 1185 X 1150	1975 X 1185 X 1150	2600 X 1185 X 1150	3850 X 1185 X 1150
Packaging Dimension (W x D x H) in mm	1508 X 1343 X 1006	2133 X 1343 X 1006	2758 X 1343 X 1006	4008 X 1343 X 1006	1508 X 1343 X 1276	2133 X 1343 X 1276	2758 X 1343 X 1276	4008 X 1343 X 1276
Weight in kg	110	170	210	310	178	214	260	350
Gross Weight in kg	140	245	295	365	210	294	350	410



ISLAND FREEZER - KORAL

FEATURES



Overhead glass cover & sliding door



LED display



Electronic temperature control with display



Wide display area with four side tempered glass



Double air curtain and high cooling efficiency



Glass door with sliding top and bottom



Adjustable temperature setting for different products



Available in different colours and sizes



Caster wheels with locks



Copper condenser and evaporator



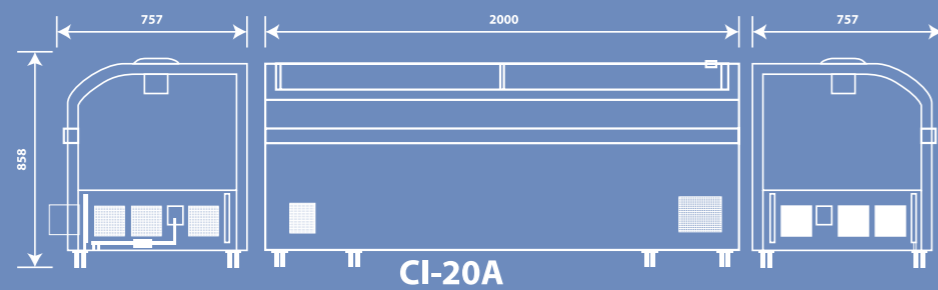
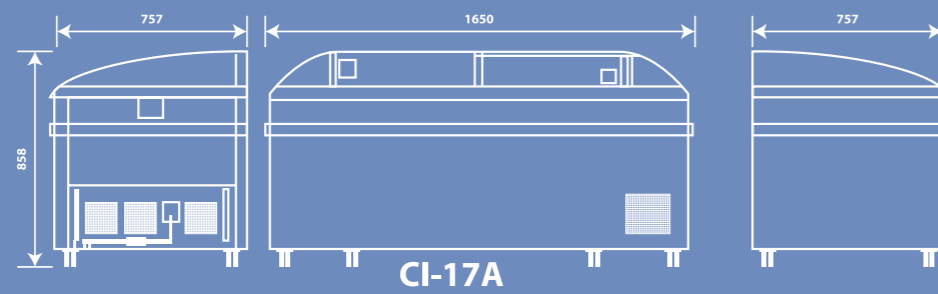
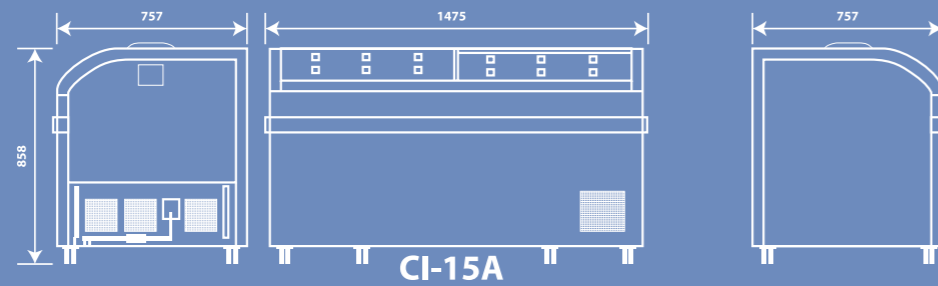

Technical Specifications

	BILF 19AEN	BILF 20AEN	BILF 19AENCG	BILF 20AENCG
Function	Freezer	Freezer	Freezer	Freezer
Size in ft	6.3	6.6	6.3	6.3
Temp Range°C	-18°C	-18°C	-18°C	-18°C
Gross capacity In Ltrs	790	890	850	900
Voltage/Frequency	220VAC~240VAC°C50Hz	220VAC~240VAC°C50Hz	220VAC~240VAC°C50Hz	220VAC~240VAC°C50Hz
Refrigerant	R290	R290	R290	R290
Condensor & Evaporator Type	Copper	Copper	Copper	Copper
Features				
Inner Tank	Prepainted Steel	Prepainted Steel	Prepainted Steel	Prepainted Steel
Basket Available	Yes	Yes	Yes	Yes
Caster Wheels	6 No.s Yes	6 No.s Yes	6 No.s Yes	6 No.s Yes
Top Glass Sliding	Top-Bottom	Top-Bottom	Left - Right	Left - Right
Light	Yes	Yes	Yes	Yes
Temp Display	Digital	Digital	Digital	Digital
Colour Option	Multiple	Multiple	Multiple	Multiple
Product Dimension(W x D x H) Inmm	1915x890x820	2000x890x880	1915x890x820	2000x890x880
Packaging Dimension(WxDxH) Inmm	1970x940x925	2055x940x985	1970x940x925	2055x940x985
Weight In Kg	113	139	130	133
Gross Weight In Kg	139	166	155	160

Note: Technical specifications are subject to change due to continuous product development.